



SUBARU



OUTBACK |



Inspiring out-of-office memos since '95.

Meet the 2025 Subaru Outback

The first Outback wasn't just a way to get out there but a reason to see something new—to have an adventure. That was 1995, and still, the Outback continues to push ahead. From its advanced technologies and safety systems to its capable engineering, this SUV lets you know the outdoors is waiting. So take a personal day—or two.

Most Adventurous

No idea is too far-out. With standard Subaru Symmetrical Full-Time All-Wheel Drive, generous ground clearance and X-MODE®, the Outback offers go-anywhere capability for adventures big and small.

Most Reliable

Built on the strength of the Subaru Global Platform, the Outback has had years of experience on all types of terrain. Durability is at the heart of its engineering, including its standard naturally aspirated and optional turbocharged SUBARU BOXER® engines¹.



Safest

The Outback takes an active role in helping you stay safe, thanks to innovations such as standard Subaru EyeSight® Driver Assist Technology² with three cameras offering enhanced capabilities and available Automatic Emergency Steering³. There's also the DriverFocus® Distraction Mitigation System^{1,4} to help reduce distracted or drowsy driving.

Most Advanced

More options come with more ease in the Outback. The large 11.6-inch tablet-style infotainment system¹ provides seamless connectivity with wireless Apple CarPlay⁵ and Android™ Auto⁶ integration. With SUBARU STARLINK® Connected Services, you have Remote Engine Start with Climate Control^{1,7}, which lets you set the perfect temperature even before you get in.

1 Availability varies by trim level. See your Subaru dealer for details. 2 EyeSight® is a driver assist technology, which may not operate optimally under all driving conditions. The driver is always responsible for safe and attentive driving. System effectiveness depends on many factors such as vehicle maintenance, weather and road conditions. See Owner's Manual for complete details on system operation and limitations. 3 Requires Subaru Side/Rear Vehicle Detection (SRVD) system. Availability varies by trim level. See your Subaru dealer for details. 4 The DriverFocus® Distraction Mitigation System is a driver recognition technology designed to alert drivers if their attention to the road wavers or if the driver's face appears to turn away. The driver is always responsible for safe and attentive driving. System effectiveness may be affected by articles of clothing worn on the head or face. See Owner's Manual for complete details on system operation and limitations. 5 Apple CarPlay® is a registered trademark of Apple Inc. 6 Android™ is a trademark of Google LLC. 7 Requires Keyless Access with Push-Button Start and subscription to SUBARU STARLINK® Connected Services. Activation with subscription required. 3-year subscription included. See your Subaru dealer for details.





**Savour that small amount
of time you spend inside.**



Farther doesn't have to feel longer.

The Outback delivers far-reaching connectivity, thanks to an 11.6-inch tablet-style infotainment system¹ and STARLINK[®] smartphone integration featuring wireless¹ Apple CarPlay^{®2} and Android^{™3} Auto³. Once everyone votes on what music to play, the Harman Kardon^{®4} premium audio system¹ will bring it to life through 12 speakers and a 576-watt-equivalent amplifier. With a standard heated steering wheel and heated front seats, along with available ventilated front seats, your comfort zone is officially dialed in.

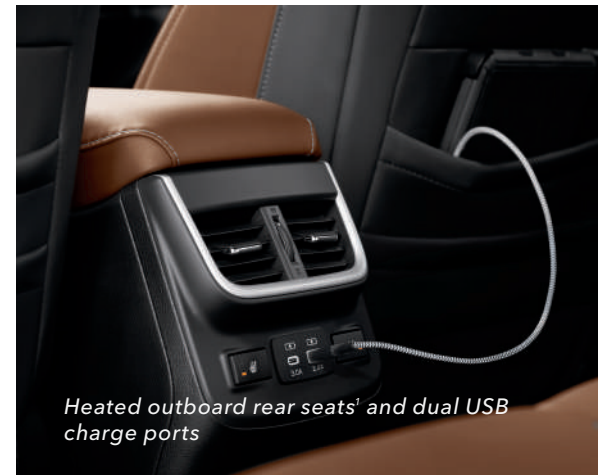

¹ Availability varies by trim level. See your Subaru dealer for details. ² Apple CarPlay[®] is a registered trademark of Apple Inc.¹ ³ Android[™] is a trademark of Google LLC¹. ⁴ Harman Kardon[®] is a registered trademark of Harman International Industries, Inc.



1 With seatback lowered. 2 Availability varies by trim level. See your Subaru dealer for details. 3 Requires Keyless Access with Push-Button Start and subscription to SUBARU STARLINK® Connected Services. Activation with subscription required. 3-year subscription included. See your Subaru dealer for details.



Rest stops aren't the only chances to stretch.

Expanding possibilities

With up to 2141 litres of cargo space¹, the Outback has room for a full range of adventures. A vast cargo area offers the convenience of a Hands-Free Power Rear Gate² and pop-up cargo cover, along with the versatility of a 60/40-split folding rear seatback. When it comes to comfort, you can ensure the Outback is at the perfect temperature even before you step in, thanks to SUBARU STARLINK® Connected Services featuring Remote Engine Start with Climate Control^{2,3}. Once inside, you're greeted by a 10-way power driver seat, heated front seats and a fully heated steering wheel. To further heighten comfort, available features include genuine Nappa leather-trimmed seating, a 12-way power driver seat, an 8-way power passenger seat and heated outboard rear seats.

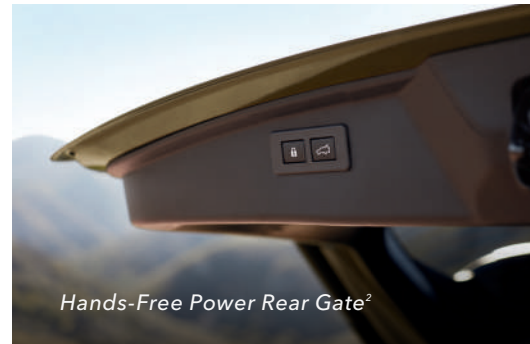

Hands-Free Power Rear Gate²



Rear-seat comfort

Find a place that makes you forget to take a selfie.

The 2025 Outback Wilderness

Your itinerary becomes anywhere in the Outback Wilderness—an Outback that's heightened, quite literally, with 241 mm of ground clearance. Its rugged front bumper cladding and grille, along with Anodized Copper-finish accents, reveal its bold nature, while its capable engineering drives the point home. For more fun while taking on the terrain, the Outback Wilderness is equipped with an enhanced dual-function X-MODE® system designed to work at higher speeds. This is combined with off-road-optimized gearing as well as approach, departure and breakover angles designed for tackling a greater variety of surfaces.





Hexagonal LED fog lights

Versatile inside and out

When you're far out there, the Outback Wilderness is designed to deliver confidence. Its ladder-type roof rails provide increased roof load capacity, while additional tow hook points and an LED rear gate light offer greater convenience. Inside, it's just as outdoor-ready, thanks to an array of functional details, including rubber floor mats and all-weather upholstery protecting the front and back seats.

Let your passion take you far.

Reliability to go the distance

Starting from its very core, the Outback is built for longevity. Subaru Symmetrical Full-Time All-Wheel Drive is the result of decades of Subaru expertise in full-time AWD engineering. The horizontally opposed design of the SUBARU BOXER® engine results in less vibration and wear and tear, and the Subaru Global Platform is simply our strongest foundation ever—incredibly durable and built to last.





182.HP

Direct Injection Boxer Engine

260.HP

Direct Injection Turbocharged Boxer Engine

Choose your engine.

With its low centre of gravity, the SUBARU BOXER engine helps to enhance performance and handling. And with the Outback, you have two options. The direct injection SUBARU BOXER engine delivers capable performance with 182 hp. For more power with efficiency, Outback XT and Outback Wilderness trims feature a 260-hp Direct Injection Turbocharged SUBARU BOXER engine with 277 lb-ft of torque. Either way, you use only the fuel you need, as standard Auto Start-Stop can shut off the engine when idling in traffic to save fuel.

An extra set of eyes every time you drive.

The Outback features the latest EyeSight® Driver Assist Technology¹, a set of systems designed to watch the road ahead, alert you and even intervene if necessary. Three cameras, including a wide-angle mono camera, provide an enhanced range of visibility to help detect vehicles, cyclists and pedestrians. Plus, EyeSight is available with Automatic Emergency Steering², which can help you avoid a collision by providing steering and pre-collision braking support if it determines there's enough space in the lane of travel to intervene.



1 EyeSight® is a driver assist technology, which may not operate optimally under all driving conditions. The driver is always responsible for safe and attentive driving. System effectiveness depends on many factors such as vehicle maintenance, weather and road conditions. The Pre-Collision Braking System is designed to provide automatic braking that either prevents a collision or reduces the severity of a frontal impact. Pre-Collision Throttle Management is designed to reduce acceleration and minimize the severity of certain frontal impacts. Lane Centring Assist is designed to assist the driver and are not substitutes for safe and attentive driving. Lane centring function operates only when used in conjunction with Adaptive Cruise Control. The Lane Departure and Sway Warning, and Lane Keep Assist operate only when the lane markings are visible, and system effectiveness depends on many factors. See Owner's Manual for complete details on system operation and limitations. 2 Requires Subaru Side/Rear Vehicle Detection (SRVD) system. Availability varies by trim level. See your Subaru dealer for details. 3 Availability varies by trim level. See your Subaru dealer for details. 4 The DriverFocus® Distraction Mitigation System is a driver recognition technology designed to alert drivers if their attention to the road wavers or if the driver's face appears to turn away. The driver is always responsible for safe and attentive driving. System effectiveness may be affected by articles of clothing worn on the head or face. See Owner's Manual for complete details on system operation and limitations.



Pre-Collision Braking¹

Can help slow and bring your Outback to a full stop if necessary.



Advanced Adaptive Cruise Control with Lane Centring¹

Automatically keeps you centred in your lane, at a safe distance behind the car in front of you—even in traffic and around curves.



Pre-Collision Throttle Management¹

Can reduce your engine power to help give you more time to react and to help minimize the possible impact force and frontal impact damage.



Lane Departure and Sway Warning with Lane Departure Prevention¹

Can alert you if you drift to the edge of your lane and begin to cross into another.



Creating safer roads by reducing distracted driving.

Subaru is taking on one of the biggest issues in the automotive industry: distracted driving. The Outback features an award-winning, state-of-the-art safety system that helps reduce distracted driving for both new and experienced drivers. Working with EyeSight¹ Driver Assist Technology, DriverFocus^{®3,4} is like having an attentive co-pilot along for the ride, ready to give a helpful alert if a driver becomes distracted or drowsy.

Detect, alert, protect.

Advanced safety features

The Outback represents the very latest in Subaru safety, down to the strong core of its Subaru Global Platform. For better visibility, there are standard LED Steering Responsive Headlights as well as an available front-view camera¹. Thanks to a wide range of active safety technologies, peace of mind is possible just about anywhere.



Blind-Spot Detection

Using radar sensors, Blind-Spot Detection^{1,2} warns you with a visual indicator on your exterior mirror if it senses a vehicle in your blind spot. Another feature of this system, Lane Change Assist, alerts you with a flashing indicator on your exterior mirror if it senses a vehicle approaching at a higher speed in a neighbouring lane and you signal for a lane change.



Rear Cross-Traffic Alert

Rear Cross-Traffic Alert^{1,2} uses radar sensors to help warn you of traffic approaching from the side as you are backing up, using a flashing visual indicator on your exterior mirror and rearview camera display as well as an audible warning.

¹ Availability varies by trim level. See your Subaru dealer for details. ² Blind-Spot Detection, Lane Change Assist and Rear Cross-Traffic Alert are systems designed to assist the driver by monitoring the rear and side areas of the vehicle during a lane change or reversing and are not a substitute for safe and attentive driving. ³ The Reverse Automatic Braking System is not a substitute for safe and attentive driving. System effectiveness depends on many factors, such as vehicle maintenance, vehicle speed, weather and road conditions. Always exercise caution and use vehicle mirrors and the rearview camera when backing up. See Owner's Manual for complete details on system operation and limitations. ⁴ Activation with subscription required.



Reverse Automatic Braking

Reverse Automatic Braking^{1,3} can detect objects directly behind your vehicle when backing up at a low speed and can help bring the Outback to a stop should an object be detected within its range and the brakes have yet to be applied. There's also the rearview camera to help you keep an eye out.



SUBARU STARLINK® Connected Services

The Outback features SUBARU STARLINK Connected Services technology^{1,4}, bringing you added safety, security and convenience. It can alert a first responder in an emergency, help police locate your vehicle if it's stolen and more. And to get you started, new Outback drivers enjoy a free three-year SUBARU STARLINK Connected Services trial, which includes Advanced Automatic Collision Notification, Enhanced Roadside Assistance, SOS Emergency Assistance and customizable vehicle alerts. It's control when you want it—and help when you need it.

2025 Outback | Features & Dimensions

11.6" tablet-style infotainment system¹



Genuine Nappa leather²



Standard LED Steering Responsive Headlights



SUBARU STARLINK® Connected Services with Remote Engine Start with Climate Control^{1,3}



Harman Kardon®⁴ 576-watt premium audio system with 12 speakers⁵



Standard EyeSight® Driver Assist Technology⁶ with wide-angle mono camera

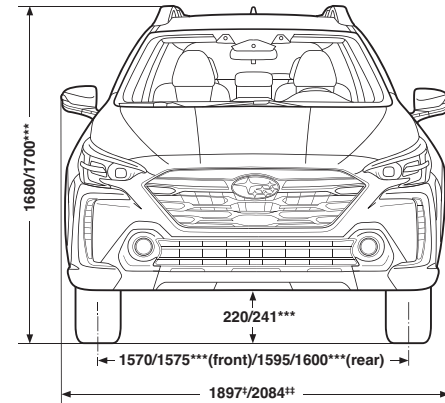
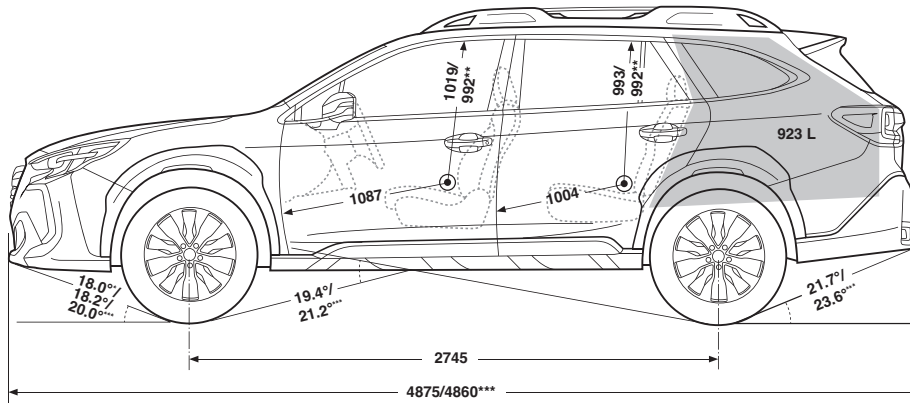

Measurements in millimetres unless specified

* Limited, Limited XT and Premier XT trims.

** With available sunroof.

*** Wilderness trim.

‡ With mirrors folded.

†† With mirrors extended.

For a detailed list of specifications, features, accessories and model comparisons, please visit Subaru.ca or your nearest authorized Subaru dealer.

1 Not available on Convenience trim. 2 Premier XT trim only. 3 Activation with subscription required. 4 Harman Kardon® is a registered trademark of Harman International Industries, Inc. 5 Not available on Convenience and Touring trims. 6 EyeSight® is a driver assist technology, which may not operate optimally under all driving conditions. The driver is always responsible for safe and attentive driving. System effectiveness depends on many factors such as vehicle maintenance, weather and road conditions. The Pre-Collision Braking System is designed to provide automatic braking that either prevents a collision or reduces the severity of a frontal impact. The Pre-Collision Throttle Management System is designed to reduce acceleration and minimize the severity of certain frontal impacts. Adaptive Cruise Control is designed to assist the driver and is not a substitute for safe and attentive driving. The Lane Departure and Sway Warning and Lane Departure Prevention Assist operate only when the lane markings are visible, and system effectiveness depends on many factors. See Owner's Manual for complete details on system operation and limitations. 7 Apple CarPlay® is a registered trademark of Apple Inc.⁷ 8 Android™ is a trademark of Google LLC.⁸ 9 Bluetooth® is a registered trademark of Bluetooth SIG, Inc., America. 10 Activation and required monthly subscription sold separately. Includes 3-month free trial subscription. See your Subaru dealer for details. SiriusXM® and the SiriusXM logo, channel names and logos are trademarks of Sirius XM Radio Inc. and are used under licence by Sirius XM Canada Inc. Subscriptions to SiriusXM Canada are subject to the SiriusXM Canada Customer Agreement and other terms & conditions. SiriusXM collects, uses and discloses your personal information according to its Privacy Policy. 11 Blind-Spot Detection, Lane Change Assist and Rear Cross-Traffic Alert are systems designed to assist the driver by monitoring the rear and side areas of the vehicle during a lane change or reversing and are not a substitute for safe and attentive driving. 12 The Reverse Automatic Braking System is not a substitute for safe and attentive driving. System effectiveness depends on many factors, such as vehicle maintenance, vehicle speed, weather and road conditions. Always exercise caution and use vehicle mirrors and the rearview camera when backing up. See Owner's Manual for complete details on system operation and limitations. 13 HomeLink® is a registered trademark of Gentex Corporation. 14 Trailer brakes may be needed. Some safety features, including X-MODE®, Blind-Spot Detection and Rear Cross-Traffic Alert, may not function properly when towing. See your Subaru dealer for details. 15 Yokohama® and Geolandar® are registered trademarks of Yokohama Tire Company. 16 The DriverFocus® Distraction Mitigation System is a driver recognition technology designed to alert drivers if their attention to the road wavers or if the driver's face appears to turn away. The driver is always responsible for safe and attentive driving. System effectiveness may be affected by articles of clothing worn on the head or face. See Owner's Manual for complete details on system operation and limitations.

2025 Outback | Trim Levels



Convenience

- 182-hp 2.5-litre 4-cylinder SUBARU BOXER® engine with direct injection
- Auto Start-Stop
- EyeSight Driver Assist Technology⁶ with wide-angle mono camera
- Subaru Symmetrical Full-Time All-Wheel Drive
- Lineartronic® CVT (Continuously Variable Transmission) with Active Torque Vectoring
- X-MODE® featuring Hill Descent Control
- LED Steering Responsive Headlights with High Beam Assist
- LED fog lights
- Roof rails with integrated retractable crossbars and 4 tie-down hooks
- Heated gloss-black exterior mirrors with integrated turn signals
- Privacy glass
- Cloth upholstery
- 10-way power-adjustable driver seat with lumbar support and 4-way manually adjustable front-passenger seat
- Heated front seats
- Leather-wrapped 360-degree heated steering wheel
- USB-A and USB-C rear seat charge ports
- Automatic climate control
- Driver and front-passenger auto-up/down power windows
- Pop-up cargo-area cover, 4 tie-down hooks and 2 grocery bag hooks
- Rearview camera with dynamic guidelines and rear washer
- Front- and rear-passenger seatbelt warning light and chime
- Dual 7-inch infotainment system with high-resolution touchscreen display, AM/FM/MP3/WMA audio system with wireless Apple CarPlay⁷ and Android™ Auto⁸ functionality, USB-A input port, auxiliary audio input, steering wheel-integrated controls, Bluetooth⁹ mobile phone connectivity with voice activation and Bluetooth⁹ streaming audio, and SiriusXM¹⁰ capability¹⁰



Onyx

Includes Touring key features and adds/upgrades:

- Dual-function X-MODE with Snow/Dirt and Deep Snow/Mud modes
- 18-inch aluminum-alloy wheels with gunmetal finish
- Gloss-black front grille
- Black badging, window mouldings and mirror trim
- Gloss-black rear spoiler
- Rear bumper step pad
- All-weather soft-touch upholstery with green contrast stitching
- Heated outboard rear seats
- Aluminum-alloy pedal covers
- All-weather floor mats
- Multi-purpose front seatback pocket
- 12-speaker, 576-watt-equivalent Harman Kardon⁴ audio system



Touring

Includes Convenience key features and adds/upgrades:

- 17-inch aluminum-alloy wheels
- Power tilting and sliding glass sunroof
- Hands-Free Power Rear Gate with vehicle lock button
- Auto-dimming exterior mirrors with approach lighting
- Windshield wiper de-icer
- Auto-up/down front and rear windows
- Dual-zone automatic climate control with synchronization
- Leather-wrapped shifter handle
- Centre console rear vents
- Cargo-area tray
- Proximity key with Push-Button Start
- Subaru Side/Rear Vehicle Detection (SRVD) system with Blind-Spot Detection and Rear Cross-Traffic Alert¹¹
- Reverse Automatic Braking¹²
- 11.6-inch tablet-style infotainment system with high-resolution touchscreen display, AM/FM/MP3/WMA audio system with wireless Apple CarPlay⁷ and Android™ Auto⁸ functionality, USB-A and USB-C input ports, auxiliary audio input, steering wheel-integrated controls, Bluetooth⁹ mobile phone connectivity with voice activation and Bluetooth⁹ streaming audio, and SiriusXM¹⁰ capability¹⁰
- SUBARU STARLINK Connected Services³ (free 3-year trial subscription included)
- EyeSight Driver Assist Technology with Automatic Emergency Steering⁶
- Auto-dimming rearview compass mirror with HomeLink¹³
- Wireless phone charger
- LED rear gate light



Limited

Includes Touring key features and adds/upgrades:

- DriverFocus⁵ Distraction Mitigation System¹⁴
- 18-inch aluminum-alloy wheels
- Silver front and rear bumper underguards
- Leather-trimmed upholstery
- 12-way power-adjustable driver seat with adjustable thigh support and 8-way power-adjustable front-passenger seat
- Two-position memory driver seat and exterior mirrors
- Heated outboard rear seats
- 11.6-inch tablet-style infotainment system with high-resolution touchscreen display, GPS navigation, AM/FM/MP3/WMA audio system with wireless Apple CarPlay⁷ and Android™ Auto⁸ functionality, USB-A and USB-C input ports, auxiliary audio input, steering wheel-integrated controls, Bluetooth⁹ mobile phone connectivity with voice activation and Bluetooth⁹ streaming audio, and SiriusXM¹⁰ capability¹⁰
- 12-speaker, 576-watt-equivalent Harman Kardon⁴ audio system

Limited XT

Includes Limited key features and adds/upgrades:

- 260-hp 2.4-litre 4-cylinder Direct Injection Turbocharged (DIT) SUBARU BOXER engine with high-torque Lineartronic CVT (Continuously Variable Transmission) and 1588 kg max towing capacity¹⁴



Wilderness

Includes Touring key features and adds/upgrades:

- 260-hp 2.4-litre 4-cylinder Direct Injection Turbocharged (DIT) SUBARU BOXER engine with high-torque Lineartronic CVT (Continuously Variable Transmission) and 1588 kg max towing capacity¹⁴
- Off-road-optimized gearing
- Enhanced dual-function X-MODE with Snow/Dirt and Deep Snow/Mud modes, low speed/low ratio gradient control and medium-to-high-speed gravel/dirt functions
- Off-road-tuned suspension with increased ground clearance
- 4 tow points with Anodized Copper-finish covers
- 17-inch aluminum-alloy wheels with matte-black finish and Yokohama¹⁵ Geolandar¹⁵ All-Terrain tires
- Hexagonal LED fog lights
- Outback Wilderness-design front and rear bumper covers, fender flares and side cladding
- Outback Wilderness-design front grille
- Matte-black, anti-glare hood decal
- Front lower skid plate
- Fixed ladder-style roof rails with increased load-carrying capacity, 4 tie-down points and Anodized Copper-finish accents
- Subaru Wilderness badging on front doors and rear gate
- Black badging and window mouldings
- Full-size spare tire
- Outback Wilderness all-weather soft-touch upholstery with Anodized Copper-finish accents and contrast stitching
- Outback Wilderness-design all-weather floor mats
- Outback Wilderness-design cargo-area tray
- Outback Wilderness gauges with colour LCD display and Anodized Copper accents
- Heated outboard rear seats
- Front-view camera
- 12-speaker, 576-watt-equivalent Harman Kardon⁴ audio system



Premier XT

Includes Limited XT key features and adds/upgrades:

- Front-view camera
- Smart auto-dimming rearview compass mirror with HomeLink¹³
- Nappa leather-trimmed upholstery
- High-grade leather-wrapped steering wheel
- Ventilated front seats
- Centre console-mounted single-disc CD player
- Automatic power-folding exterior mirrors with satin chrome finish
- Silver-accented roof rails with integrated retractable crossbars and 4 tie-down hooks
- Chrome-accented exterior door handles

2025 Outback | Colours

Exterior Colours

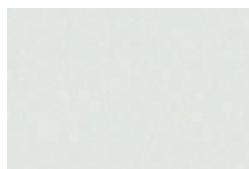

Crystal White Pearl



Ice Silver Metallic

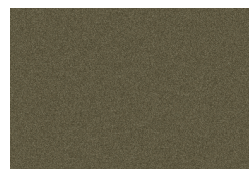

Autumn Green Metallic

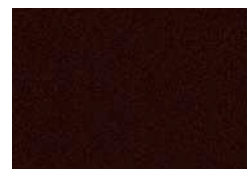

Dark Mahogany Pearl

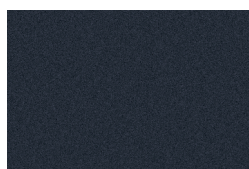

Cosmic Blue Pearl

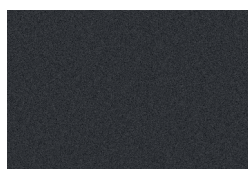

Magnetite Grey Metallic

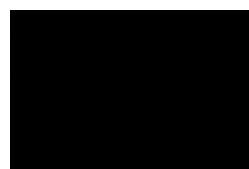

Crystal Black Silica



Geyser Blue

Seat Material

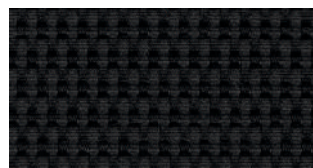

Black Cloth (BC)



Grey All-Weather Soft-Touch Upholstery (GST)

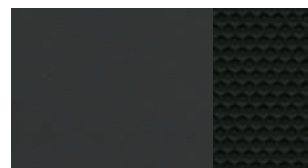

Wilderness Grey All-Weather Soft-Touch Upholstery (WGST)

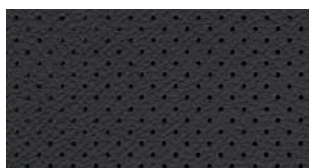

Black Leather (BL)



Platinum Leather (PL)

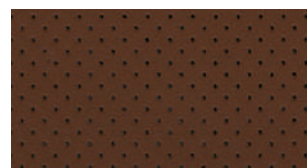

Brown Nappa Leather (BRN)

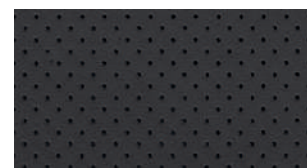

Black Nappa Leather (BNL)

Colour Combinations	Convenience	Touring	Onyx	Wilderness	Limited and Limited XT	Premier XT
Crystal White Pearl	BC	BC	GST	WGST	BL	BRN or BNL
Ice Silver Metallic	BC	BC	–	–	BL	BNL
Autumn Green Metallic	–	BC	GST	WGST	BL	BRN or BNL
Dark Mahogany Pearl	–	BC	–	–	BL	BNL
Cosmic Blue Pearl	BC	BC	GST	–	BL or PL	BRN or BNL
Magnetite Grey Metallic	BC	BC	GST	WGST	BL	BRN or BNL
Crystal Black Silica	BC	BC	GST	WGST	BL	BRN or BNL
Geyser Blue	–	–	–	WGST	–	–



Subaru Warranties

Every Subaru vehicle is designed and built to offer our customers the highest possible level of quality and reliability. We are proud of our vehicles and proud to stand behind them with a comprehensive warranty. For 2025 model-year vehicles, the warranty on all Subaru vehicles consists of the following:

New Vehicle Limited Warranty (36 month/60,000 km) – Covers basic and major components for 36 months or 60,000 km.

Major Component Limited Warranty (60 month/100,000 km) – Extends coverage of major components (more than just powertrain) up to 60 months or 100,000 km.

Surface Corrosion Limited Warranty (36 month/60,000 km) – Covers surface corrosion to visible painted body panels for 36 months or 60,000 km.

Anti-Perforation Limited Warranty (60 month/unlimited km) – Covers perforation due to corrosion to body sheet metal panels for 60 months, regardless of kilometres.

Emission Control System Limited Warranty – Covers some emissions components for 36 months or 60,000 km and the major parts of the emission control system for 96 months or 130,000 km.

Parts and Accessories Limited Warranty – Covers Subaru parts and accessories installed by the Subaru dealer prior to retail delivery of the vehicle for 36 months or 60,000 km, and Subaru parts and accessories installed by the Subaru dealer after the retail delivery of the vehicle for 12 months or 20,000 km from the date of the installation.

The above information is an overview of warranty coverage and is not a warranty statement. If you wish to see more details regarding Subaru warranties, please refer to your Subaru warranty booklet, contact your local Subaru dealer or visit our Web site at subaru.ca.

Subaru 360 C.A.R.E. Program (36 months/unlimited km)

Access to dedicated Subaru 360 C.A.R.E. (Customer Assistance for Roadside Emergencies) Roadside Assistance Services, which includes access to 1,000 CAA and AAA offices throughout Canada and the United States. In addition to towing, coverage also includes Fuel Delivery, Battery Boost, Flat Tire Service, Lock-Out Service, Trip Accident & Mechanical Breakdown Assistance Service, Winching and Extrication Service, Personalized Trip Planning and Routing, Theft and Hit-and-Run Reward, and Arrest Bond Certificate.

The above information is an overview of services. If you wish to see more details regarding Subaru 360 C.A.R.E., please visit our Web site at subaru.ca.

Subaru Protection Plan

As a Subaru owner, you have expectations for a pleasurable, trouble-free ownership experience – now and into the future. Once your 36-month/60,000-km New Vehicle Limited Warranty period ends¹, our Subaru Protection Plan (SPP) – the only vehicle service contract endorsed by Subaru Canada for Subaru vehicles – can prolong your hassle-free ownership experience with three levels of extended service contract coverage tailored to your needs: Powertrain Protection; Major Protection; or Complete Protection (best level of coverage to complement the 60-month/100,000-km Major Component Limited Warranty). SPP offers comprehensive mechanical and electrical coverage and a number of additional features and benefits, such as Roadside Assistance and Alternate Transportation, for up to 7 years or 160,000 kilometres from your vehicle's in-service date. Whether your vehicle is purchased or leased, SPP protects you and your investment. Be sure to ask your Subaru dealer for details or visit subaru.ca.

¹ If you already own a Subaru vehicle and it is still within the 36-month/60,000-km New Vehicle Limited Warranty period, you are still eligible for SPP.

Subaru vehicles are uniquely designed to get out there more and to leave less behind. We build our vehicles for maximum longevity, because more time spent on the road equals less time spent in junkyards and landfills. In fact, 96% of Subaru vehicles sold in Canada over the last 10 years are still on the road today¹. You'll also find very little waste created in the production of a Subaru. Many of our vehicles are built in the Subaru of Indiana Automotive, Inc., (SIA) factory, which was the first manufacturing facility in the U.S. to achieve zero-landfill status. Other Subaru facilities around the world now achieve similar goals in helping to preserve the environment. Respect for our surroundings is yet another way that Subaru vehicles help to build driver confidence for the road ahead.

¹ Based on IHS Markit Vehicles in Operation as of June 30, 2022, for Model Years 2013 to 2022 vs. Total New Registrations of those vehicles.



For a detailed list of specifications, features, accessories and model comparisons, please visit Subaru.ca or your nearest authorized Subaru dealer.

The Supplemental Restraint System (SRS airbags) affords the driver and passenger additional protection in some collisions. This system provides supplemental protection only, and seatbelts must be worn in order to avoid injuries to out-of-position occupants upon airbag deployment. The combination of SRS and seatbelts provides the best protection in a serious accident. All illustrations, specifications, features and photographs contained in this brochure are based on product information available at the time of its printing and may not be completely accurate following its publication. Colours shown may vary due to reproduction variations in the printing process, and some vehicle parts cannot be shown in certain photographs. Subaru Canada, Inc. reserves the right to discontinue or make changes at any time, without notice or incurring obligations, to colours, materials, equipment, accessories, features, specifications and models, or to change their prices. Some models shown may be from international markets and are not available in Canada; may be shown with equipment or accessories that are optional (at extra cost) or available only in certain combinations; or may be subject to product delays or not be available in Canada. Please visit subaru.ca for the latest information and specifications. For complete details on product updates and warranties, please contact your Subaru dealer. Ascent, BRZ, Crosstrek, Forester, Impreza, Legacy, Outback, Solterra, WRX, STI, DriverFocus, EyeSight, Lineartronic, STARLINK, Subaru, SUBARU BOXER, SUBARU STARLINK, and X-MODE are registered trademarks of SUBARU CORPORATION. Android™ is a trademark of Google LLC¹. Apple CarPlay® is a registered trademark of Apple Inc.² Bluetooth® is a registered trademark of Bluetooth SIG, Inc., America. Harman Kardon® is a registered trademark of Harman International Industries, Inc. HomeLink® is a registered trademark of Gentex Corporation. SiriusXM® and the SiriusXM logo, channel names and logos are trademarks of Sirius XM Radio Inc. and are used under licence by Sirius XM Canada Inc. Subscriptions to SiriusXM Canada are subject to the SiriusXM Canada Customer Agreement and other terms & conditions. SiriusXM collects, uses and discloses your personal information according to its Privacy Policy. Yokohama® and Geolandar® are registered trademarks of Yokohama Tire Corp. † Ability of this product to access connected content is subject to change without notice and could be affected by any of the following: compatibility issues with future firmware versions of the smartphone; compatibility issues with future versions of the connected content application(s) for the smartphone; changes to or discontinuation of the connected content application(s) or service by its provider. Printed in Canada. © 2024 Subaru Canada, Inc. 2025 model year.



Environmental Management System
(EMS) ISO 14001:2015 certified by SGS

This brochure was printed on certified paper and contains recycled fibre. It is chlorine-free, recyclable and biodegradable. It was produced using a "Green Printing Process" which includes vegetable-based inks that make this brochure fully recyclable leaving no harmful residue. Please recycle.



PROCESS CERTIFIED FOR REDUCED
ENVIRONMENTAL IMPACT. VIEW
SPECIFIC ATTRIBUTES EVALUATED:
UL2891

subaru.ca

SUBARU CANADA, INC.

560 Suffolk Court, Mississauga, ON, L5R 4J7