



SUBARU

SOLTERRA





1. EyeSight Driver Assist Technologies may not operate optimally under all driving conditions. The driver is always responsible for safe and attentive driving. System effectiveness depends on many factors such as vehicle maintenance, weather and road conditions. See your Owner's Manual for complete details on system operation and limitations. 2. The DriverFocus Distraction Mitigation System is a driver recognition technology designed to alert drivers if their attention to the road wavers or if the driver's face appears to turn away. The driver is always responsible for safe and attentive driving. System effectiveness may be affected by articles of clothing worn on the head or face. See your Owner's Manual for complete details on system operation and limitations. 3. Front Cross-Traffic Alert is a system designed to assist the driver by monitoring the front area of the vehicle when moving forward and is not a substitute for safe and attentive driving. See your Owner's Manual for complete details on system operation and limitations. 4. Based on Natural Resources Canada's (NRCan) approved guidelines. Refer to NRCan's Fuel Consumption Guide available at <https://fcr-ccc.nrcan-rncan.gc.ca/en> for more information. Full battery charge and ideal conditions are required. Figures will vary based, amongst others and non-exclusively, on driving and charging habits, speed, accessory use, weather and temperature, battery age, vehicle condition, road condition and other factors. In sub ideal conditions, figures may worsen by more than 50%. Battery capacity decreases with time and use which will further reduce range. See the Owner's Manual or NRCan's Fuel Consumption Guide for details. 5. Charging times and capacities are estimated based on ideal charging conditions and infrastructure. As temperatures decrease below 10°C, charging time will increase significantly and charging capacity will decrease significantly. Charging may slow down more than other comparable models in weather conditions below 0°C and may not be possible when the battery temperature drops to around -20°C and below. Amongst others and non-exclusively, drive battery conditions, charger specifications, charging infrastructure and Level 3 DC fast charging fully more than once per day also can negatively affect charging time. See the Owner's Manual for details. 6. Apple CarPlay® is a registered trademark of Apple Inc. 7. Android™ is a trademark of Google LLC. 8. Availability varies by trim level. See your Subaru dealer for details. 9. See subaru.ca for full subscription details.



Adventure Innovated.

Meet the 2024 Solterra.

It's all-electric, the first Subaru SUV of its kind. But make no mistake, the 2024 Solterra is a Subaru, first and foremost. That means you can expect capable engineering, versatile space and the latest advancements in keeping you safe. This isn't just any battery-powered SUV, it's the one that can power your next adventure.

Adventurous & Versatile

There are other electric SUVs, but only the Solterra has standard Subaru Symmetrical All-Wheel Drive. This is paired with the smooth, linear output of dual electric motors, delivering impressive torque on demand, thanks to the intelligent design of Subaru StarDrive® technology. With X-MODE®, Grip Control and 210 mm of ground clearance, the Solterra is ready for whatever comes with the terrain.

Safe & Trusted

The Solterra is built on the strong e-Subaru Global Platform and engineered to our high standards of longevity and safety. EyeSight® Driver Assist Technologies¹ come standard and now include automatic lane changing, hands-free driving at lower speeds and the ability to resume driving automatically once traffic starts moving again. Plus, there are newly added safety technologies like the DriverFocus® Distraction Mitigation System² and Front Cross-Traffic Alert³. For even more peace of mind, there's also an available 360-degree surround-view camera system.

Eco-Friendly

Up to 359 km of EV range with the capability of standard AWD feels good⁴. Zero emissions feels even better. And when you're able to charge at home overnight, it's like starting every day with a "full tank." Thanks to its DC fast-charging capability, the Solterra can achieve an approximate 10% to 80% charge from 60 minutes when conditions are ideal⁵.

Intuitive & Comfortable

The spacious, well-connected Solterra caters to trips of all sizes. With standard wireless Apple CarPlay®⁶ and Android™⁷ Auto integration, you can easily access your music and apps cord-free. Vehicle information is laid out right in front of you on a full LCD instrument cluster and an available 12.3-inch Subaru Multimedia display⁸. For even more convenience, the Subaru Solterra Connect™ app lets you remotely turn on and adjust your climate controls⁹, check your charge status and find nearby charging stations.

All-electric goes all places.

Both versatile and capable, with standard Subaru Symmetrical All-Wheel Drive and 210 mm of ground clearance, the Solterra can add to your list of possible destinations. Delivering a capable 249 lb-ft of torque, its dual electric motors create a noticeably smooth, linear output. To take on steep, slippery terrain, there's standard dual-function X-MODE® with hill descent assist. And to handle your gear, there's up to 674 litres of cargo volume^{1,2}, along with a 60/40 split-folding rear seatback. Loading is simplified by a low load-in height, wide rear gate opening and roof rails with cross bar mounting points. Plus, you can opt for a power rear gate³ for even greater ease when it's time to pack up.





1. With rear seatback raised. 2. Cargo capacity varies by cargo floor height. Minimum value with cargo floor in highest position shown. 3. Availability varies by trim level. See your Subaru dealer for details. 4. With rear seatback lowered.

An extra set of eyes every time you drive.

Every Solterra includes standard EyeSight® Driver Assist Technologies¹.





Collision Avoidance Assist with Automatic Steering¹

Collision Avoidance Assist with Automatic Steering can provide automatic steering and pre-collision braking support if it senses potential danger ahead and determines there's enough space to intervene.



Pre-Collision System¹

A driver ahead unexpectedly hits the brakes or cuts you off. The Pre-Collision System warns you, applies brakes and, at lower speeds, can even help you stop your Solterra.



Dynamic Radar Cruise Control with Lane Tracing Assist¹

This system can automatically keep you centred in your lane, safely behind the car in front of you—even in traffic and around curves. This system now includes automatic lane changing, hands-free driving at lower speeds and the ability to resume driving automatically once traffic starts moving again.



Lane Departure Alert¹

You accidentally drift to the edge of your lane and begin to cross into another. Lane Departure Alert watches for lane markers and can alert you with visual and audible warnings before you leave your lane. It can even help steer you back into your proper course.



Acceleration Suppression at Low-Speed¹

This system reduces accelerator sensitivity to help you avoid accidentally accelerating into the car in front of you while merging or if you unintentionally put your Solterra in Drive instead of Reverse.

¹ EyeSight® Driver Assist Technologies may not operate optimally under all driving conditions. The driver is always responsible for safe and attentive driving. System effectiveness depends on many factors such as vehicle maintenance, weather and road conditions. See your Owner's Manual for complete details on system operations and limitations.



Blind-Spot Monitor

Using radar sensors, Blind-Spot Monitor³ warns you with a visual indicator on your exterior mirror if it senses a vehicle in your blind spot. This system also alerts you with a flashing indicator on your exterior mirror if it senses a vehicle approaching at a higher speed in a neighbouring lane and you signal for a lane change.



Front and Rear Cross-Traffic Alert

The Front and Rear Cross-Traffic Alert³ systems use radar sensors to help warn you of traffic approaching from the side as you are moving forward and backing up, utilizing a flashing visual indicator on your exterior mirror and rearview camera display as well as an audible warning.

1 Safe Exit Assist (SEA) is designed to assist vehicle occupants by detecting approaching vehicles to help reduce door-opening accidents. If an approaching vehicle is detected, the system will display a warning light on the door mirror. If an occupant opens the door to exit, the system provides additional visual warning on the meter display and an audible alert. Safe Exit Assist will not prevent the door from opening and is not a substitute for safe, attentive exiting. See your Owner's Manual for complete details on system operation and limitations. 2 Availability varies by trim level. See your Subaru dealer for details. 3 Blind-Spot Monitor, Front Cross-Traffic Alert and Rear Cross-Traffic Alert are systems designed to assist the driver by monitoring the front, rear and side areas of the vehicle while moving forward, reversing or during a lane change, and are not a substitute for safe and attentive

Peace of mind is possible.

We gave the Solterra our latest advancements in safety, from its technologies to its body structure. It's built on the strong e-Subaru Global Platform with strategically placed crumple zones to help protect you and your passengers. Smartly designed systems like Safe Exit Assist¹ and a 360-degree surround-view camera offer extra reassurance². Plus, a host of active safety systems are available to help provide better all-around awareness.



Creating safer roads by reducing distracted driving.

Subaru is taking on one of the biggest issues in the automotive industry: distracted driving. The Solterra features an award-winning, state-of-the-art safety system that helps reduce distracted driving for both new and experienced drivers. Working with EyeSight[®] Driver Assist Technologies, DriverFocus^{®5} is like having an attentive co-pilot along for the ride, ready to give a helpful alert if a driver becomes distracted or drowsy.



Parking Support Brake

Parking Support Brake⁴ can detect objects directly behind your vehicle when backing up at a low speed and can help bring the Solterra to a stop if it detects an object within its range and the brakes have yet to be applied. Plus, Parking Support Brake is available with pedestrian detection⁴ for even greater peace of mind and there's a standard rearview camera to help you keep an eye out.



Safe Exit Assist

After you park the Solterra, Safe Exit Assist¹ can help avoid a potential door-opening accident by detecting approaching vehicles or moving objects and delivering an initial alert on the mirror. This is followed by additional visual and auditory alerts if you begin to open your door.

driving. ⁴ Parking Support Brake and Parking Support Brake with pedestrian detection are not substitutes for safe and attentive driving. System effectiveness depends on many factors, such as vehicle maintenance, pedestrian speed, weather and road conditions. Always exercise caution and use vehicle mirrors and the rear camera when backing up. See your Owner's Manual for complete details on system operation and limitations. ⁵ The DriverFocus Distraction Mitigation System is a driver recognition technology designed to alert drivers if their attention to the road wavers or if the driver's face appears to turn away. The driver is always responsible for safe and attentive driving. System effectiveness may be affected by articles of clothing worn on the head or face. See your Owner's Manual for complete details on system operation and limitations.



Do not connect or disconnect the plug if your hands are wet, and do not get the plug or outlet wet. Do not charge vehicle when there is possibility of lightning. See your Owner's Manual for complete details on system operation and limitations.



Doing your part is simpler than you think.

The Solterra not only produces zero emissions, it also streamlines electric driving. Its lithium-ion battery offers up to 359 km of driving range in ideal conditions¹, along with the flexibility of alternating- or direct-current charging options. So, you can charge your Solterra at the office, on the go, or at home overnight—just like you do with your phone. Thanks to its DC fast-charging capability, the Solterra can achieve an approximate 10% to 80% charge from 60 minutes when conditions are ideal². With Subaru StarDrive® technology, you have options tailored to your driving experience, including paddle shifter-controlled regenerative braking, Power and Eco modes, plus S-Pedal Drive³—with additional regenerative braking power to help reduce the fatigue of switching between the accelerator and brake pedals.

¹ Based on Natural Resources Canada's (NRCAN) approved guidelines. Refer to NRCAN's Fuel Consumption Guide available at <https://fcr-ccc.nrcan-rncan.gc.ca/en> for more information. Full battery charge and ideal conditions are required. Figures will vary based, amongst others and non-exclusively, on driving and charging habits, speed, accessory use, weather and temperature, battery age, vehicle condition, road condition and other factors. In sub ideal conditions, figures may worsen by more than 50%. Battery capacity decreases with time and use which will further reduce range. See the Owner's Manual or NRCAN's Fuel Consumption Guide for details. ² Charging times and capacities are estimated based on ideal charging conditions and infrastructure. As temperatures decrease below 10°C, charging time will increase significantly and charging capacity will decrease significantly. Charging may slow down more than other comparable models in weather conditions below 0°C and may not be possible when the battery temperature drops to around -20°C and below. Amongst others and non-exclusively, drive battery conditions, charger specifications, charging infrastructure and Level 3 DC fast charging fully more than once per day also can negatively affect charging time. See the Owner's Manual for details. ³ S-Pedal Drive is not a substitute for safe and attentive driving. The driver must press the brake pedal to come to a complete stop. See your Owner's Manual for complete system operation and details.



**Find quality time
anywhere.**

If the journey is long, the Solterra can make it feel that much shorter. Its 3384 litres of interior space¹ is strategically optimized to convey an open feel, while its nearly flat floor and generous rear-seat legroom help keep your passengers content. You can also opt for a panoramic glass roof², easy-to-clean StarTex[®] upholstery², heated and ventilated front seats², heated rear seats², a heated steering wheel² and a new 8-way power-adjustable front passenger seat². For everyone's enjoyment, an available 11-speaker, 576-watt-equivalent Harman Kardon^{®3} premium audio system² delivers crisp, clear sound.

1 Interior volume varies by trim level and load floor height. Maximum volume shown. See your Subaru dealer for details. 2 Availability varies by trim level. See your Subaru dealer for details. 3 Harman Kardon[®] is a registered trademark of Harman International Industries, Inc.



Panoramic glass roof²



Heated rear seats² and USB-C ports



Harman Kardon^{®2} premium audio system²



Tech without the learning curve.

Intuitive designs keep you connected in the Solterra. Standard wireless Apple CarPlay^{®1} and Android^{™2} Auto integration let you access your music and apps, and thoughtful conveniences let you charge your smartphone wirelessly^{3,4}. Important vehicle information is readily available on a full LCD gauge cluster and the available 12.3-inch infotainment system display⁴. If it's time to recharge your Solterra, your Subaru Multimedia system can help provide directions to the nearest charging station⁵. With the Subaru Solterra Connect[™] app, you can access available features that allow you to control the vehicle temperature, check your charge status and more⁶.



1 Apple CarPlay® is a registered trademark of Apple Inc.¹ 2 Android™ is a trademark of Google LLC.² 3 Qi wireless charging may not be compatible with all mobile devices. When using the wireless charging system, avoid placing metal objects between the wireless charger and the mobile device when charging is active. Doing so may cause metal objects to become hot and could cause burns. 4 Availability varies by trim level. See your Subaru dealer for details. 5 Drive Connect subscription required. See your Subaru dealer for details. 6 See subaru.ca for full subscription details.

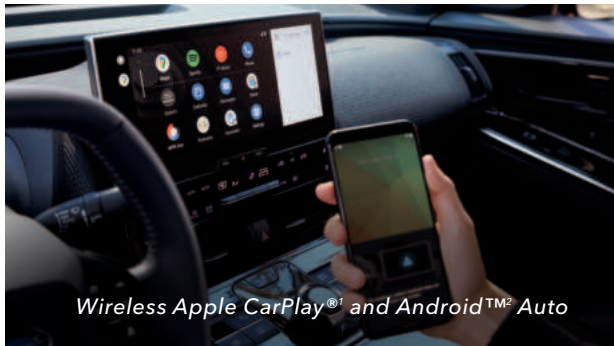

Wireless Apple CarPlay®¹ and Android™² Auto



Wireless phone charging^{3,4}



A photograph of a dirt path winding through a lush green forest. Sunlight filters through the dense canopy of trees, creating a dappled light effect on the path and the surrounding grass and moss. The path leads into the distance, flanked by large, mature trees with thick trunks. The overall atmosphere is serene and natural.

Only a Subaru is engineered like a Subaru.

Confidence and capability are at the core of every Subaru, and the Solterra is no different. It's engineered to provide consistent traction in almost any condition, thanks to Subaru Symmetrical Full-Time All-Wheel Drive. And it's built on a rigid body structure—a hallmark of Subaru vehicles—that offers better handling, control and comfort. These are all reasons why 96% of our vehicles sold in Canada over the last 10 years are still on the road today¹.

¹ Based on IHS Markit Vehicles in Operation as of June 30, 2022, for Model Years 2013 to 2022 vs. Total New Registrations of those vehicles.

2024 Solterra | Features & Dimensions

20-inch Aluminum-alloy Wheels¹



LED Headlamps with Auto High Beam (AHB)



Split roof spoiler with aerodynamic fins¹



Rear seat USB-C ports and heated outboard seats¹



12.3-inch Centre Display¹



High-speed wireless phone charging^{1,2}

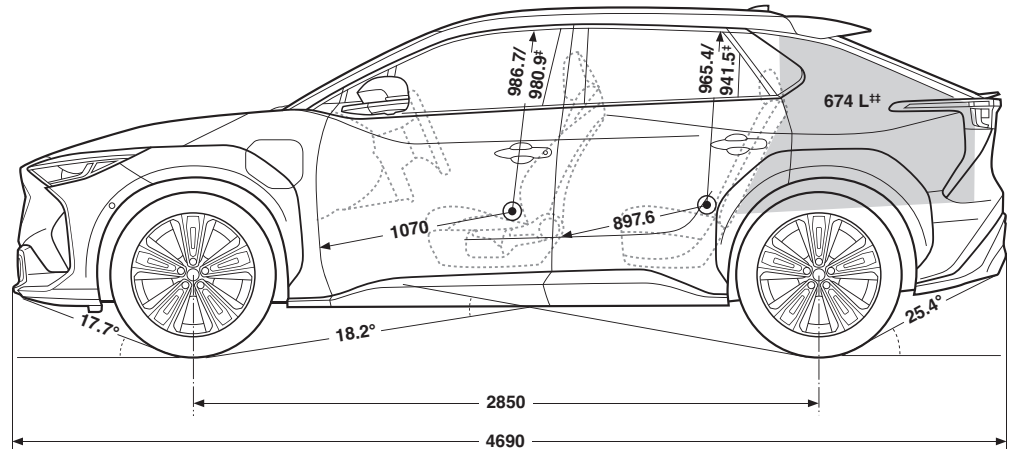
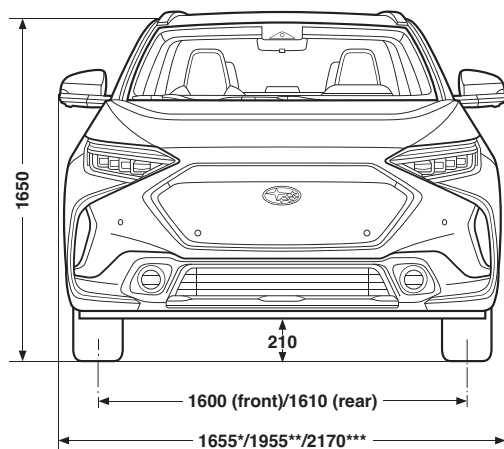

Measurements in millimetres

* Excluding mirrors.

** With mirrors folded.

*** With mirrors extended.

† With panoramic glass roof.

‡ Minimum value with cargo floor in highest position.

For a detailed list of specifications, features, accessories, and model comparisons, please visit Subaru.ca or your nearest authorized Subaru Dealer.

¹ Solterra AWD with Luxury Package and Solterra AWD with Technology Package only. See your Subaru dealer for details. ² Qi wireless charging may not be compatible with all mobile devices. When using the wireless charging system, avoid placing metal objects between the wireless charger and the mobile device when charging is active. Doing so may cause metal objects to become hot and could cause burns. ³ EyeSight® Driver Assist Technologies may not operate optimally under all driving conditions. The driver is always responsible for safe and attentive driving. System effectiveness depends on many factors such as vehicle maintenance, weather and road conditions. See your Owner's Manual for complete details on system operation and limitations. ⁴ Drive Connect subscription required. See your Subaru dealer for details. ⁵ Apple CarPlay® is a registered trademark of Apple Inc.¹ ⁶ Android™ is a trademark of Google LLC.¹ ⁷ Activation and required monthly subscription sold separately. Includes 3-month free trial subscription. See your Subaru dealer for details. SiriusXM® and the SiriusXM logo, channel names and logos are trademarks of Sirius XM Radio Inc. and are used under licence by Sirius XM Canada Inc. Subscriptions to SiriusXM Canada are subject to the SiriusXM Canada Customer Agreement and other terms & conditions. SiriusXM collects, uses and discloses your personal information according to its Privacy Policy. ⁸ Bluetooth® is a registered trademark of Bluetooth SIG, Inc., America. ⁹ Blind-Spot Monitor, Front Cross-Traffic Alert and Rear Cross-Traffic Alert are systems designed to assist the driver by monitoring the front, rear and side areas of the vehicle while moving forward, reversing or during a lane change, and are not a substitute for safe and attentive driving. ¹⁰ Safe Exit Assist (SEA) is designed to assist vehicle occupants by detecting approaching vehicles to help reduce door-opening accidents. If an approaching vehicle is detected, the system will display a warning light on the door mirror. If an occupant opens the door to



Solterra AWD

- SUBARU StarDrive® all-electric drivetrain, front and rear 80 kW electric motors
- Subaru Symmetrical Full-Time All-Wheel Drive
- Dual-function X-MODE® with Grip Control
- 210 mm of ground clearance
- EyeSight® Driver Assist Technologies³
- Auto-on/off LED Headlights with automatic high beams
- 18-inch aluminum-alloy wheels with aerodynamic wheel covers
- Heated, Galactic Black finish exterior mirrors
- Roof rails, Galactic Black finish
- Privacy glass
- Proximity Key with Push-Button Start
- Cloth upholstery
- 6-way manually adjustable driver and front-passenger seats
- 4-mode heated front seats
- Leather-wrapped steering wheel with integrated controls
- 8.0-inch infotainment system with cloud-based navigation⁴, wireless Apple CarPlay^{®5} and Android^{™6} Auto integration, SiriusXM[®] capability⁷, dual illuminated USB-C input ports, 6 speakers, AM/FM stereo, Bluetooth^{®8} audio streaming and hands-free phone connectivity, and auxiliary jack
- 7.0-inch digital instrument cluster
- Dual-zone automatic climate control
- Auto-up/down power windows front and rear
- Automatic anti-glare rearview mirror
- 60/40 split-folding and reclining rear seatback
- 4 tie-down hooks and 2 grocery bag hooks
- Front- and rear-passenger seatbelt warning light/chime and rear-seat reminder
- Dual illuminated USB-C rear seat charge ports
- Welcome lighting
- Level 2 combination charging cable
- Blind-Spot Monitor⁹
- Front and Rear Cross-Traffic Alert⁹
- Safe Exit Assist¹⁰
- Parking Support Brake¹¹
- DriverFocus[®] Distraction Mitigation System¹²
- Solterra Connect[™] enabled¹³: Includes features and services such as Advanced Collision Notification, Remote Climate Control, vehicle charge status, vehicle health reports and more
- Subaru Parking Assist: Includes front and rear parking sensors, and rear camera with washer



Solterra AWD with Luxury Package

Includes Solterra AWD key features and adds/upgrades:

- 20-inch aluminum-alloy wheels
- LED fog lights
- Roof spoiler with integrated fins
- Mono- and Two-tone exterior paint schemes¹⁴
- Power Rear Gate with height memory and vehicle lock button
- Power-folding exterior mirrors with integrated turn signals, cameras and foot lighting
- Automatic tilt-down passenger side mirror
- Perforated, StarTex[®]-trimmed upholstery
- 10-way power-adjustable driver seat with lumbar support, 8-way power-adjustable front-passenger seat
- Two-position memory driver seat and exterior mirrors
- 3-mode heated steering wheel
- 3-mode heated outboard rear seats
- 12.3-inch infotainment system with cloud-based navigation⁴, wireless Apple CarPlay^{®5} and Android^{™6} Auto integration, SiriusXM[®] capability⁷, dual illuminated USB-C input ports, AM/FM stereo, Bluetooth^{®8} audio streaming and hands-free phone connectivity, and auxiliary jack
- Harman Kardon^{®15} premium audio system with 576-watt-equivalent amplifier and 11 speakers
- High-speed wireless phone charging²
- Panoramic View Monitor 360-degree camera system
- Advanced Park driver parking assistance¹⁶
- Parking Support Brake with pedestrian detection¹¹
- Rain-sensing windshield wipers
- Automatic anti-glare rearview mirror with HomeLink^{®17}



Solterra AWD with Technology Package

Includes Solterra AWD key features and adds/upgrades:

- 20-inch aluminum-alloy wheels
- LED fog lights
- Roof spoiler with integrated fins
- Mono- and Two-tone exterior paint schemes¹⁴
- Gloss black hood insert, B-pillar and rear-door finish panels
- Fixed glass moonroof with sunshade
- Power Rear Gate with height memory and vehicle lock button
- Proximity Key Entry (all doors)
- Power-folding exterior mirrors with integrated turn signals, cameras and foot lighting
- Automatic tilt-down passenger side mirror
- Perforated, StarTex[®]-trimmed upholstery
- 10-way power-adjustable driver seat with lumbar support, 8-way power-adjustable front-passenger seat
- Two-position memory driver seat and exterior mirrors
- 4-mode ventilated front seats
- 3-mode heated steering wheel
- 3-mode heated outboard rear seats
- 12.3-inch infotainment system with cloud-based navigation⁴, wireless Apple CarPlay^{®5} and Android^{™6} Auto integration, SiriusXM[®] capability⁷, dual illuminated USB-C input ports, AM/FM stereo, Bluetooth^{®8} audio streaming and hands-free phone connectivity, and auxiliary jack
- Harman Kardon^{®15} premium audio system with 576-watt-equivalent amplifier and 11 speakers
- High-speed wireless phone charging²
- Digital rearview mirror with HomeLink^{®17}
- Front and rear interior ambient lighting, doors and footwells
- Panoramic View Monitor 360-degree camera system
- Advanced Park driver parking assistance¹⁶
- Parking Support Brake with pedestrian detection¹¹
- Rain-sensing windshield wipers
- Retractable cargo-area cover

exit, the system provides additional visual warning on the meter display and an audible alert. Safe Exit Assist will not prevent the door from opening and is not a substitute for safe, attentive exiting. See your Owner's Manual for complete details on system operation and limitations. ¹¹ Parking Support Brake (PKSB) and Parking Support Brake (PKSB) with pedestrian detection are not substitutes for safe and attentive driving. System effectiveness depends on many factors, such as vehicle maintenance, weather and road conditions. Always exercise caution and use vehicle mirrors and the rear camera when backing up. See your Owner's Manual for complete details on system operation and limitations. ¹² The DriverFocus Distraction Mitigation System is a driver recognition technology designed to alert drivers if their attention to the road wavers or if the driver's face appears to turn away. The driver is always responsible for safe and attentive driving. System effectiveness may be affected by articles of clothing worn on the head or face. See your Owner's Manual for complete details on system operation and limitations. ¹³ Subscription required. See subaru.ca for full subscription details. ¹⁴ Availability varies by vehicle colour. See your Subaru dealer for details. ¹⁵ Harman Kardon[®] is a registered trademark of Harman International Industries, Inc. ¹⁶ Advanced Park is a system designed to assist the driver in parking situations using cameras and sensors to help guide the vehicle into parking spots. This system is not a substitute for safe and attentive driving. System effectiveness depends on many factors, such as vehicle maintenance, weather and road conditions. Always exercise caution and keep an eye on vehicle surroundings, mirrors and camera systems when parking. See Owner's Manual for complete details on system operation and limitations. ¹⁷ HomeLink[®] is a registered trademark of Gentex Corporation.

2024 Solterra | Colours

Exterior Colours

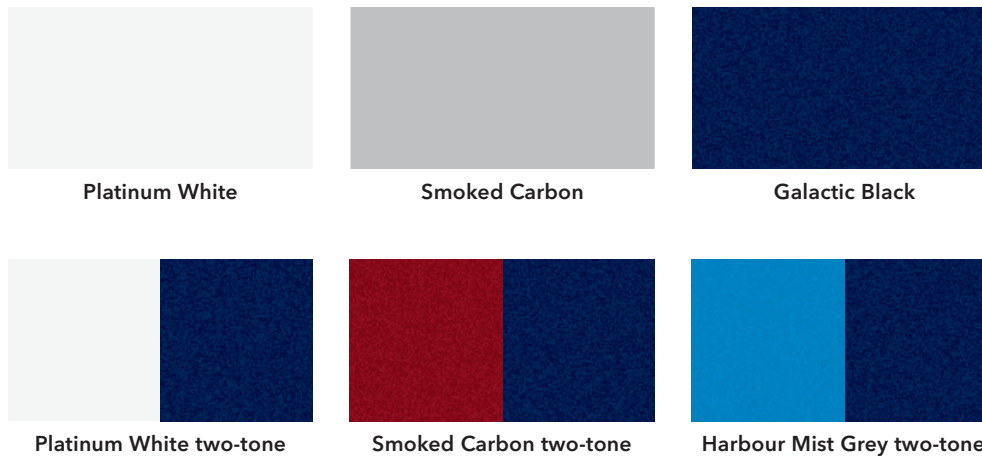

Seat Material

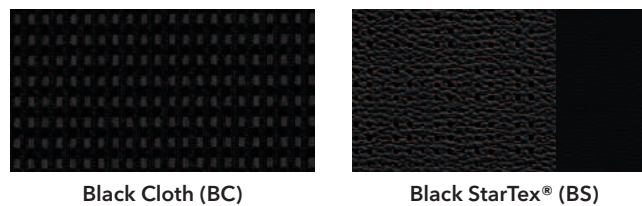

Colour Combinations	Solterra AWD	Solterra AWD with Luxury Package	Solterra AWD with Technology Package
Platinum White	BC	BS	BS
Platinum White two-tone	–	BS	BS
Smoked Carbon	BC	BS	BS
Smoked Carbon two-tone	–	BS	BS
Harbour Mist Grey two-tone	–	BS	BS
Galactic Black	BC	BS	BS



Subaru Warranties

Every Subaru vehicle is designed and built to offer our customers the highest possible level of quality and reliability. We are proud of our vehicles and proud to stand behind them with a comprehensive warranty. For 2024 model-year vehicles, the warranty on all Subaru vehicles consists of the following:

New Vehicle Limited Warranty (36 month/60,000 km) – Covers basic and major components for 36 months or 60,000 km.

Major Component Limited Warranty (60 month/100,000 km) – Extends coverage of major components (more than just powertrain) up to 60 months or 100,000 km.

Surface Corrosion Limited Warranty (36 month/60,000 km) – Covers surface corrosion to visible painted body panels for 36 months or 60,000 km.

Anti-Perforation Limited Warranty (60 month/unlimited km) – Covers perforation due to corrosion to body sheet metal panels for 60 months, regardless of kilometres.

Battery and Electric Drive Unit Limited Warranty – Covers the major parts of the battery and electric drive unit for 96 months or 160,000 km.

Parts and Accessories Limited Warranty – Covers Subaru parts and accessories installed by the Subaru dealer prior to retail delivery of the vehicle for 36 months or 60,000 km, and Subaru parts and accessories installed by the Subaru dealer after the retail delivery of the vehicle for 12 months or 20,000 km from the date of the installation.

The above information is an overview of warranty coverage and is not a warranty statement. If you wish to see more details regarding Subaru warranties, please refer to your Subaru warranty booklet, contact your local Subaru dealer or visit our Web site at subaru.ca.

Subaru 360 C.A.R.E. Program (36 months/unlimited km)

Access to dedicated Subaru 360 C.A.R.E. (Customer Assistance for Roadside Emergencies) Roadside Assistance Services, which includes access to 1,000 CAA and AAA offices throughout Canada and the United States. In addition to towing, coverage also includes Fuel Delivery, Battery Boost, Flat Tire Service, Lock-Out Service, Trip Accident & Mechanical Breakdown Assistance Service, Winching and Extrication Service, Personalized Trip Planning and Routing, Theft and Hit-and-Run Reward, and Arrest Bond Certificate.

The above information is an overview of services. If you wish to see more details regarding Subaru 360 C.A.R.E., please visit our Web site at subaru.ca.

Subaru Protection Plan

As a Subaru owner, you have expectations for a pleasurable, trouble-free ownership experience – now and into the future. Once your 36-month/60,000-km New Vehicle Limited Warranty period ends¹, our Subaru Protection Plan (SPP) – the only vehicle service contract endorsed by Subaru Canada for Subaru vehicles – can prolong your hassle-free ownership experience with three levels of extended service contract coverage tailored to your needs: Powertrain Protection; Major Protection; or Complete Protection (best level of coverage to complement the 60-month/100,000-km Major Component Limited Warranty). SPP offers comprehensive mechanical and electrical coverage and a number of additional features and benefits, such as Roadside Assistance and Alternate Transportation, for up to 7 years or 160,000 kilometres from your vehicle's in-service date. Whether your vehicle is purchased or leased, SPP protects you and your investment. Be sure to ask your Subaru dealer for details or visit subaru.ca.

¹ If you already own a Subaru vehicle and it is still within the 36-month/60,000-km New Vehicle Limited Warranty period, you are still eligible for SPP.

Subaru vehicles are uniquely designed to get out there more and to leave less behind. We build our vehicles for maximum longevity, because more time spent on the road equals less time spent in junkyards and landfills. In fact, 96% of our vehicles sold in Canada over the last 10 years are still on the road today¹. You'll also find very little waste created in the production of a Subaru. Many of our vehicles are built in the Subaru of Indiana Automotive, Inc., (SIA) factory, which was the first manufacturing facility in the U.S. to achieve zero-landfill status. Other Subaru facilities around the world now achieve similar goals in helping to preserve the environment. Respect for our surroundings is yet another way that Subaru vehicles help to build driver confidence for the road ahead.

¹ Based on IHS Markit Vehicles in Operation as of June 30, 2022, for Model Years 2013 to 2022 vs. Total New Registrations of those vehicles.



For a detailed list of specifications, features, accessories, and model comparisons, please visit Subaru.ca or your nearest authorized Subaru Dealer.

The Supplemental Restraint System (SRS airbags) affords the driver and passenger additional protection in some collisions. This system provides supplemental protection only, and seatbelts must be worn in order to avoid injuries to out-of-position occupants upon airbag deployment. The combination of SRS and seatbelts provides the best protection in a serious accident. All illustrations, specifications, features, and photographs contained in this brochure are based on product information available at the time of its printing and may not be completely accurate following its publication. For the most up-to-date and detailed product information, log on to www.subaru.ca. Subaru Canada, Inc. has made every effort to ensure that the digital colours displayed offer the most accurate representation of actual vehicle colours. Digital colours shown may not accurately depict colours as they appear in person because of screen quality or viewing light. Some vehicle parts cannot be shown in certain photographs. For complete details on vehicle parts and colours, please contact your Subaru dealer. Subaru Canada, Inc. reserves the right to discontinue or make changes at any time, without notice or incurring obligations, to colours, materials, equipment, accessories, features, specifications, and models or to change their prices. Some models shown may be from international markets and are not available in Canada; may be shown with equipment or accessories that are optional (at extra cost) or available only in certain combinations; or may be subject to product delays or not be available in Canada. Please visit subaru.ca for the latest information and specifications. For complete details on product updates and warranties, please contact your Subaru dealer. Ascent, BRZ, Crosstrek, Forester, Impreza, Legacy, Outback, Solterra, WRX, STI, DriverFocus, EyeSight, Lineartronic, SI-DRIVE, STARLINK, Subaru, SUBARU BOXER and X-MODE are registered trademarks of SUBARU CORPORATION. Subaru Solterra Connect is a trademark of SUBARU CORPORATION. StarDrive is a trademark of Subaru of America, Inc. StarTex is a registered trademark of Subaru of America, Inc. Android™ is a trademark of Google LLC[†]. Apple CarPlay® is a registered trademark of Apple Inc.[†] Bluetooth® is a registered trademark of Bluetooth SIG, Inc., America. Harman Kardon® is a registered trademark of Harman International Industries, Inc. HomeLink® is a registered trademark of Gentex Corporation. Qi® is a registered trademark of Wireless Power Consortium, Inc. SiriusXM® and the SiriusXM logo, channel names and logos are trademarks of Sirius XM Radio Inc. and are used under licence by Sirius XM Canada Inc. Subscriptions to SiriusXM Canada are subject to the SiriusXM Canada Customer Agreement and other terms & conditions. SiriusXM collects, uses and discloses your personal information according to its Privacy Policy.

[†] Ability of this product to access connected content is subject to change without notice and could be affected by any of the following: compatibility issues with future firmware versions of the smartphone; compatibility issues with future versions of the connected content application(s) for the smartphone; changes to or discontinuation of the connected content application(s) or service by its provider.

© 2024 Subaru Canada, Inc. 2024 model year.

subaru.ca

SUBARU CANADA, INC.

560 Suffolk Court, Mississauga, ON, L5R 4J7